



## Walltransform

3 Melbourne Close  
Marton  
Middlesbrough  
Cleveland TS7 8NL

Tel: 01642 272848 Fax: 01642 503666  
e-mail: glen.melvin@nitworld.com  
website: www.walltransform.co.uk

**Agrément  
Certificate  
No 02/3951**

Designated by Government  
to issue  
European Technical  
Approvals

## WALLREFORM

Enduit de surface  
Oberflächenbeschichtung

## Product



• THIS CERTIFICATE RELATES TO WALLREFORM, AN INSULATING RENDER FOR INTERNAL AND EXTERNAL WALLS, CONSISTING OF CEMENT, EXPANDED POLYSTYRENE BEADS AND OTHER ADDITIVES.

• The product is applied to internal or external walls of masonry or dense concrete construction and is suitable for use on new or existing buildings.

• Application must be carried out by trained operatives strictly in accordance with the marketing company's instructions and this Certificate.

• The product is manufactured and marketed by Walltransform.

## Regulations

### 1 The Building Regulations 2000 (as amended) (England and Wales)

 The Secretary of State has agreed with the British Board of Agrément the aspects of performance to be used by the BBA in assessing the compliance of wall finishes with the Building Regulations. In the opinion of the BBA, Wallreform, if used in accordance with the provisions of this Certificate, will meet or contribute to meeting the relevant requirements.

Requirement: B2  
Requirement: B4(1)

Internal fire spread (linings)  
External fire spread

Comment:

The product meets these Requirements. See sections 10.1 and 10.2 of this Certificate.

Requirement: C4

Resistance to weather and ground moisture

Comment:

A wall treated with the product and a suitable finish will meet the Requirement. See sections 9.1 and 9.2 of this Certificate.

Requirement: L1  
Requirement: L2

Conservation of fuel and power in dwellings  
Conservation of fuel and power in buildings other than dwellings

Comment:

The product will contribute towards enabling a wall to meet the U value requirement. See sections 11.1 to 11.4 of this Certificate.

Requirement: Regulation 7

Materials and workmanship

Comment:

Wallreform is an acceptable material. See section 14.1 of this Certificate.

# Electronic Copy

## 2 The Building Standards (Scotland) Regulations 1990 (as amended)



In the opinion of the BBA, Wallreform, if used in accordance with the provisions of this Certificate, will satisfy or contribute to satisfying the various Regulations and related Technical Standards as listed below.

Regulation:	10	Fitness of materials and workmanship
Standard:	B2.1	Selection and use of materials, fittings, and components, and workmanship
Comment:		Wallreform is an acceptable material. See section 14.1 of this Certificate.
Regulation:	12	Structural fire precautions
Standard:	D7.1	Fire spread on internal linings
Standard:	D10.1	Fire spread on an external wall
Comment:		The product has a low risk surface, as defined in the <i>Provisions deemed to satisfy the standards</i> , section (D1.3) of the Technical Standards, and is unrestricted by these Standards. See sections 10.1 and 10.2 of this Certificate.
Regulation:	17	Resistance to moisture
Standard:	G3.1	Resistance to precipitation
Comment:		A wall treated with the product and a suitable finish coat will satisfy the requirements of this Standard. See sections 9.1 and 9.2 of this Certificate.
Regulation:	18	Resistance to condensation
Standard:	G4.1	Interstitial condensation
Comment:		A wall treated with the product and a suitable finish coat will satisfy the requirements of this Standard. See sections 9.1 and 9.2 of this Certificate.
Regulation:	22	Conservation of fuel and power
Standard:	J3.1	Building fabric — Standards for buildings in purpose group 1
Standard:	J8.1	Buildings other than dwellings – Buildings in Purpose Groups 2 to 7
Comment:		The product will contribute towards enabling a wall to meet these Standards. See sections 11.1 to 11.4 of this Certificate.

## 3 The Building Regulations (Northern Ireland) 2000



In the opinion of the BBA, Wallreform, if used in accordance with the provisions of this Certificate, will satisfy or contribute to satisfying the various Building Regulations as listed below.

Regulation:	B2	Fitness of materials and workmanship
Comment:		Wallreform is an acceptable material. See section 14.1 of this Certificate.
Regulation:	C4	Resistance to ground moisture and weather
Regulation:	C5	Condensation
Comment:		A wall treated with the product and a suitable finish will meet these requirements. See sections 9.1 and 9.2 of this Certificate.
Regulation:	E3	Internal fire spread — Linings
Regulation:	E5	External fire spread
Comment:		The product is unrestricted by these Regulations. See sections 10.1 and 10.2 of this Certificate.
Regulation:	F2	Building fabric
Comment:		The product will contribute towards enabling a wall to meet this Regulation. See sections 11.1 to 11.4 of this Certificate.

## 4 Construction (Design and Management) Regulations 1994 (as amended)

### Construction (Design and Management) Regulations (Northern Ireland) 1995 (as amended)

Information in this Certificate may assist the client, planning supervisor, designer and contractors to address their obligations under these Regulations.

See sections: 6 *Delivery and site handling* (6.1 and 6.5) and 18 *Procedure* (18.5).

## Technical Specification

### 5 Description

5.1 Wallreform is a cement-based render base coating, containing expanded polystyrene beads and other additives. Two separate components are supplied, a powder element and the beads.

5.2 The product is manufactured in a batch-blending process. Quality control is exercised over raw materials and on the final product.

5.3 Application involves preparation of the substrate to receive Wallreform and adjustments to building elements, such as window sill extensions, alterations to gable details and downpipes and fixing of beads, as required.

5.4 The render is applied by hand or spray machine, to suitably prepared substrates, in a single coat to a thickness of up to 40 mm to suit the insulation requirement.

5.5 The system may be finished externally with any high-build masonry coating or plastic rendering covered by an Agrément Certificate. A standard plaster mix may be used to provide an internal finish.

5.6 Ancillary items include exterior grade plastic sections used to provide details such as corner beads, stop beads, bellcast drip beads, reinforcing mesh and expansion joint. Where required, a vinyl acetate-ethylene copolymer emulsion is used as a bonding aid.

### 6 Delivery and site handling

6.1 The product is supplied as two components sealed in a single bag with a total weight of 12.24 kg.

6.2 Wallreform should be stored in dry, internal conditions on pallets. The bags should be used in rotation.

6.3 Unopened bags may be stored for up to one year.

6.4 Each bag bears the product identification, batch number, date of manufacture, the NESTA<sup>(1)</sup> logo and the BBA identification mark incorporating the number of this Certificate.

(1) The National Endowment for Science, Technology and the Arts.

6.5 The product is cement based and must be handled following the routine precautions as used for Portland cement.

## Design Data

### 7 General

7.1 When installed in accordance with this Certificate, Wallreform, when finished with any high-build masonry coating or plastic rendering covered by an Agrément Certificate, is satisfactory for external use over traditional sand/cement render, brickwork, blockwork and concrete substrates prepared and

suiting to receive a rendered finish. It is essential that walls to receive the product are designed and constructed in relation to local exposure conditions to minimise the incidence of rain penetration and condensation.

7.2 Walls to be rendered with the product should be designed and constructed in accordance with the relevant recommendations of BS 5628-3 : 2001 (in particular, section 3 *Design*, clause 21 on exclusion of moisture) and BS 5262 : 1991 (in particular, section 3 *Design*, clauses 18, 27 and 29 on conditions of exposure, resistance to cracking and protection afforded by architectural features). The designer should select a construction appropriate to its location paying due attention to design detailing, workmanship (including the relevant sections of BS 8000-10 : 1995) and materials to be used.

7.3 This Certificate covers use of the product over the area of the wall above damp-proof course level. Wallreform has not been assessed for use:

on woodwool slabs

over timber-frame construction

over metal-frame construction

on the backs of parapet and screenwalls rendered on the face

on horizontal surfaces exposed to the weather, such as ledges, sills and copings

as rendering to chimney stacks

as rendering to Sol bricks.

7.4 The product with finish coating will provide a new decorative finish and improve the weather resistance of a wall.

7.5 The product may also be applied internally where it should be finished with a standard plaster mix.

### 8 Strength and stability

8.1 The product may be taken as equivalent to Type II renders to BS 5262 : 1991 and has adequate resistance to impact damage and cracking. Where there is a risk of severe impact, eg some industrial sites, or where application has been made over existing background cracks, precautions may be required to reduce the risk of damage.

8.2 In common with traditional renders, it is essential that the surface to be rendered provides a sound mechanical key to ensure a satisfactory bond between the substrate and the product.

### 9 Weather resistance



9.1 Walls to receive an application of the product must be designed and constructed in relation to local exposure conditions to minimise the incidence of rain penetration.

9.2 Wallreform finished with an Agrément certificated high-build masonry coating or plastic rendering will tend to shed water and reduce considerably the amount of water absorbed by the substrate during rain.

## 10 Performance in relation to fire

 10.1 When tested in accordance with BS 476-6 : 1989, Wallreform has a fire propagation index (I) of 4.3 with sub-index ( $i_1$ ) of 2.0 and, when tested to BS 476-7 : 1997, has a Class 1 surface. Therefore, it has a Class 0 surface or low-risk surface as defined in the various national Building Regulations.

10.2 High-build coatings or plastic renderings covered by Agrément certification should be selected to maintain this rating.

## 11 Thermal insulation

 11.1 The  $\lambda$  value (thermal conductivity) of Wallreform when tested by a guarded hotplate test conforming to BS 874-2.1 : 1986 is  $0.055 \text{ Wm}^{-1}\text{K}^{-1}$  at a density of  $204.6 \text{ kgm}^{-3}$  and a thickness of 40.2 mm.

11.2 The requirement for limiting the heat loss through the building fabric will be satisfied if the U values of the building elements, including thermal bridging, do not exceed the maximum values in the relevant Elemental Approach given in:

### *England and Wales*

Approved Document L1 or L2

### *Scotland*

Part J3 or J8 of the Technical Standards

### *Northern Ireland*

Technical Booklet F.

11.3 Where insulation has not been continued into window or door reveals, due to a lack of clearance, there will be a risk of cold bridging. Where door and window frames are to be replaced it is recommended that their size be adjusted to permit the reveals to be insulated.

11.4 Depending on constructional details, cold bridging can also occur at the eaves and at ground-floor level, and care should be taken to minimise this, eg roof or loft insulations should continue over the wall head. Care should be taken to ensure that ventilation openings are not obstructed.

## 12 Risk of interstitial condensation

12.1 Wallreform has a water vapour resistance such that, under the conditions likely to be found in dwellings in the United Kingdom, interstitial condensation should not occur within it.

12.2 If the Wallreform is to be used on the external walls of rooms expected to have continuous high humidities, additional measures may need to be taken to avoid possible problems from the formation of the interstitial condensation in the wall.

## 13 Maintenance and repair

Damage to the system should be repaired immediately and repairs should be carried out in accordance with the relevant recommendations of BS 5262 : 1991. Regular maintenance checks should be carried out on architectural details for shedding water and on

external plumbing and fittings to prevent penetration of water into the rendering, or discolouration of the surface.

## 14 Durability

 14.1 Wallreform applied in accordance with this Certificate to a suitable substrate and finished with an Agrément certificated high-build masonry coating or plastic rendering will perform satisfactorily for a period in excess of 20 years.

14.2 The finishes may become discoloured with time, the rate depending on the initial colour, the degree of exposure and atmospheric pollution, and the design and detailing of the wall.

## Installation

### 15 Site survey and preliminary work

15.1 Advice to the contractor/installer is available from the Certificate holder.

15.2 A pre-application survey of the property is carried out to determine its suitability to receive the product and whether repairs to the building structure are necessary before application. This should include an assessment on the suitability of the substrate. A specification is prepared by the Certificate holder or an approved installer, for each elevation, indicating:

preliminary treatment of the background

the position of the beads

detailing around windows, doors and at eaves

damp-proof course level

exact position of movement joints

areas where flexible sealants may be used

any alterations to external plumbing.

15.3 Tests in accordance with BS 3921 : 1985 may be necessary to determine the salt content of brick substrates. Results of the test should be reported to the Certificate holder to enable them to advise on the suitability of the substrates to receive the product.

15.4 All necessary repairs to the building structure are completed before application.

15.5 It may be necessary to make alterations to the underground drainage to accommodate the changed position of rainware on the new surface.

15.6 On existing buildings purpose-made over-sills may be necessary to extend beyond the finished face of the product. Sills should have an efficient throat or drip on the underside and be designed to prevent water running onto the wall below, or into the jambs. New buildings should incorporate suitably wide sills.

15.7 Before rendering, new walls should be left as long as possible to minimise substrate movement. A minimum period of three months is preferred.

### 16 Approved applicators

Application of the product and finishes is carried out by approved applicators; an approved applicator being a company which:

(1) is approved by Walltransform to apply the system,

(2) is employing operatives who have been trained and approved by Walltransform to install/apply the product and who have been issued with appropriate certification by Walltransform,

(3) has undertaken to comply with Walltransform application procedures which contain the requirements for each application team to include at least one member with a Walltransform certificate or training card, and

(4) is subject to site inspection by Walltransform. The contractors/installers will also be subject to site inspections by the BBA, as appropriate.

## 17 Preparation of substrate

17.1 All damage to the substrate caused by frost attack, salts or corrosion must be carefully repaired. Damaged bricks or blocks must be replaced and any holes, or insufficiently filled joints, repaired. Loose and spalling render or projecting mortar joints should be removed and uneven surfaces must be levelled to avoid variations in the thickness of the product.

17.2 The relevant recommendations of BS 5262 : 1991 must be followed if a satisfactory bond is to be achieved. In particular, the surface to be rendered must provide a good mechanical key and adequate suction and be free from paint, oil, soot, lichens, moulds and similar growth or anything (including efflorescence and dust) likely to prevent a satisfactory bond.

17.3 When the substrate consists of different materials or a material of variable suction, the recommendations of BS 5262 : 1991 and the manufacturer's instructions must be followed to ensure even quality and appearance of the product.

17.4 On backgrounds of negligible suction the advice of the Certificate holder should be sought concerning special precautions necessary to provide an adequate key.

17.5 Wherever possible independent scaffolding should be used to avoid the need to subsequently make good putlog holes and other breaks in the work.

## 18 Procedure

### External use

18.1 Application is carried out in accordance with the Certificate holder's instructions.

18.2 Application must not be carried out where the air or wall surface temperature is below 5°C or above 30°C.

18.3 The bellcast drip bead trim is fixed above the dpc level to form the base of the product (see Figure 1), with the stop bead trim fixed at junctions between properties. Corner beads are fixed at corners and the sides of windows, and the mechanical fixings applied at a spacing of from 300 mm to 600 mm.

Figure 1 Detail at dpc

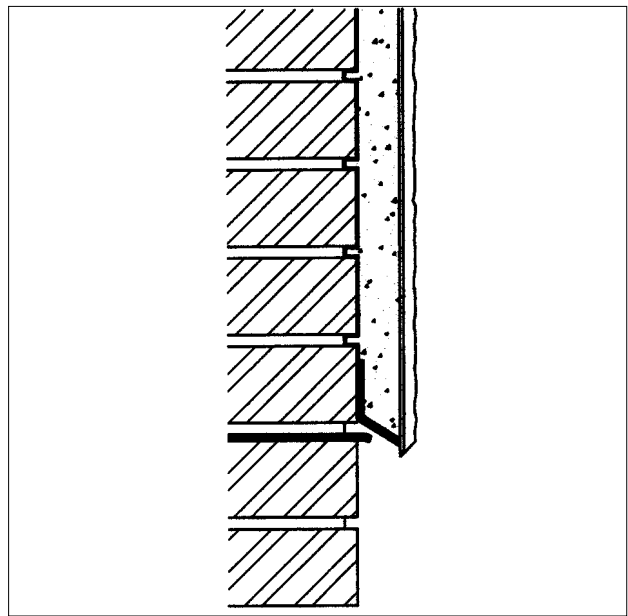

18.4 The product may be applied to various substrates in accordance with BS 8000-10 : 1995 and BS 5262 : 1991. For painted brickwork, painted render or when adhesion to the substrate is considered suspect, metal laths or ribbed expanded mesh formwork covered by Agrément certification should be fixed over the entire area in accordance with the relevant Certificate.

18.5 The product is prepared for use by mixing the two components with approximately 2 litres of water using an efficient paddle mixer or similar until a uniform consistency is achieved. Hand mixing may be carried out for small amounts.

18.6 When all the preparatory work is complete, the product is applied, either by hand or by using spray equipment, in coats as required. Where mesh is required, particularly at openings (see Figure 2), a bedding coat should be applied; care being taken to ensure the render is fully integrated into the mesh.

18.7 The render should be applied evenly to produce the required thickness (one bag at a thickness of 40 mm should cover approximately 1.2 m<sup>2</sup>).

18.8 After approximately 24 hours a topcoat may be applied to obtain the desired finish and appearance.

18.9 Although temperature and humidity have only a limited effect on the product, care should be taken to protect Wallreform and the coatings from too rapid drying due to exposure to direct sun or drying wind. Care must also be taken to protect these products from rain, mist or cold conditions (less than 5°C on a falling thermometer), when drying may be excessively prolonged<sup>(1)</sup>. Continuous surfaces must be completed without break.

(1) Reference should be made to the coating manufacturer's recommendations.

18.10 At the tops of walls, the Wallreform and coating must be protected by an adequate overhang

or by an adequately sealed purpose-made flashing (see Figures 3, 4 and 5).

18.11 Movement joints in the wall must be continued through the Wallreform and coating. A vertical joint detail using purpose-made metal trims is shown in Figure 6.

18.12 At openings, coatings should be continued around reveals to a thickness dependent on clearances. New buildings should be built to allow for this. Where there is insufficient clearance, advice should be sought from the manufacturer.

Figure 2 Additional reinforcement at openings

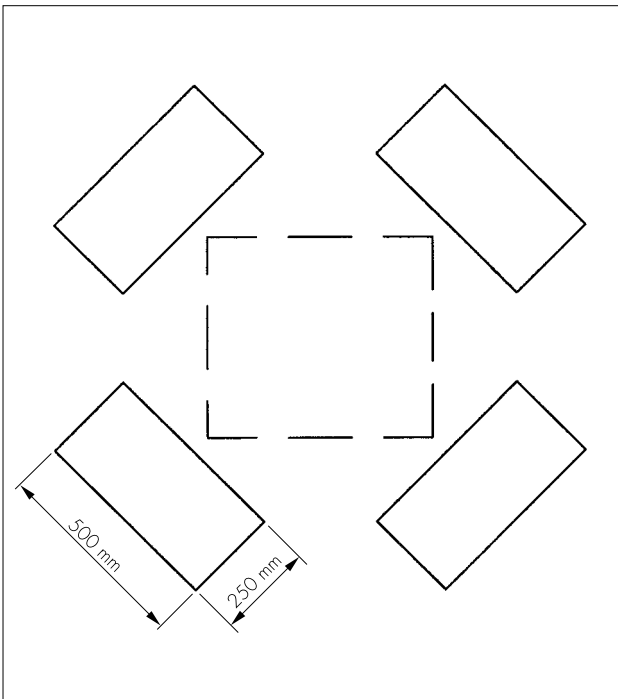

Figure 3 Eaves detail — pitched roof

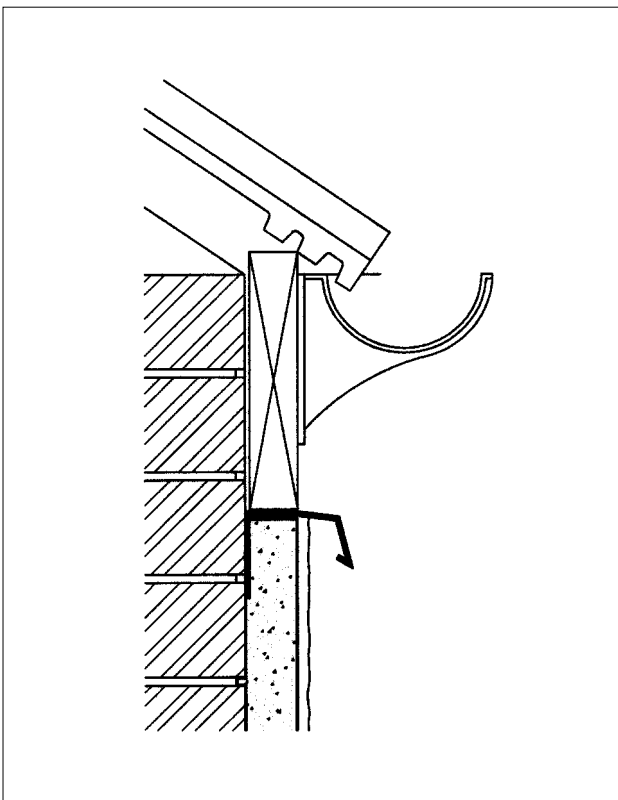

Figure 4 Verge detail — pitched roof

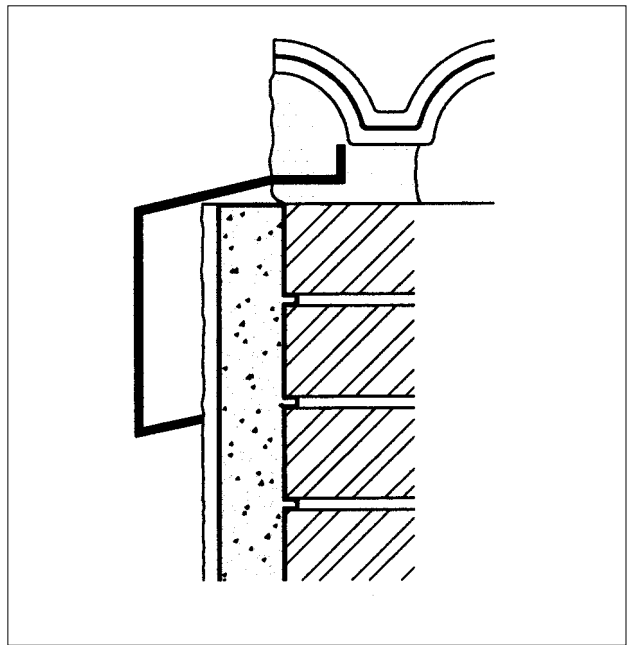

Figure 5 Edge detail — flat roof

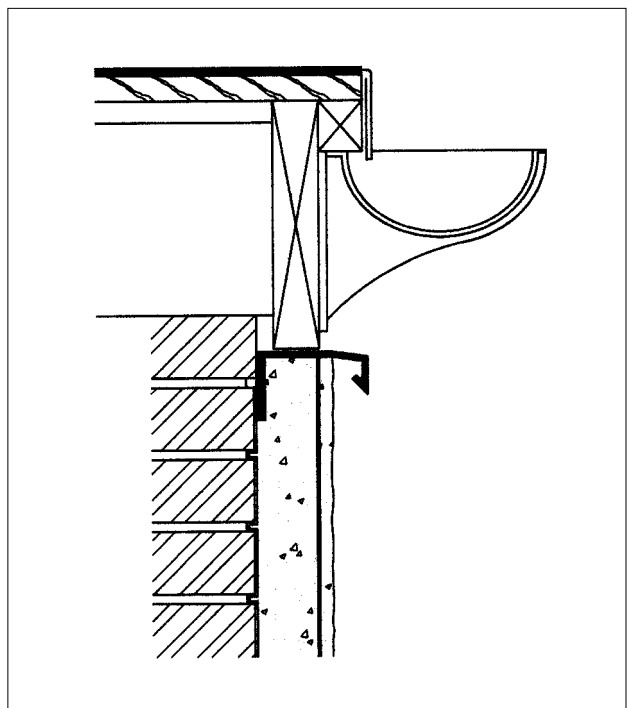
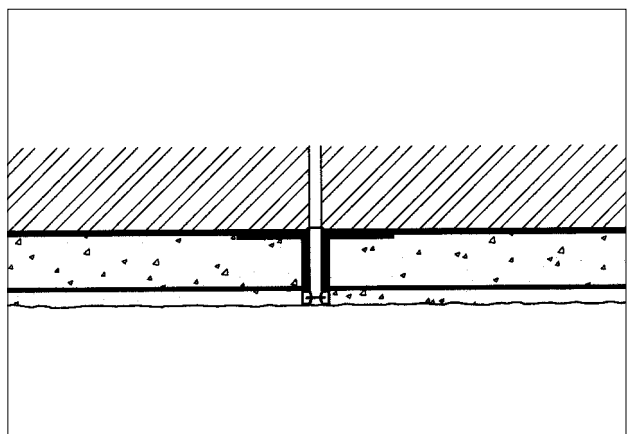

Figure 6 Movement joint detail



18.13 Care must be taken in detailing joints and seals around openings and projections (see Figures 7 and 8).

Figure 7 Window sill detail

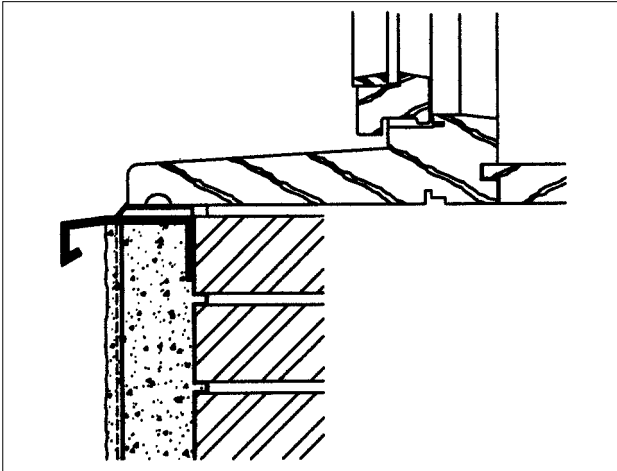
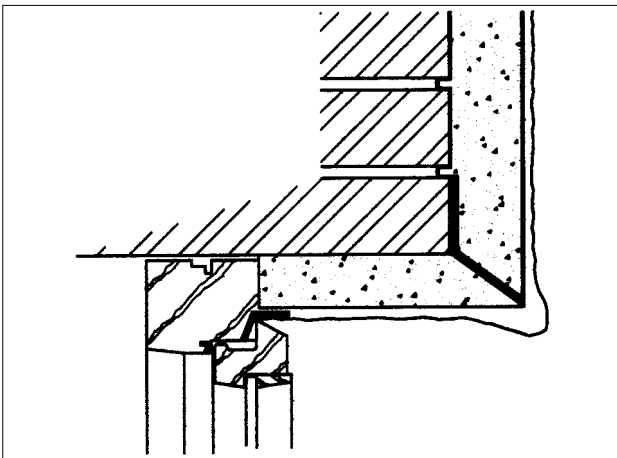

Figure 8 Window head detail



18.14 On completion, external fittings are re-fixed to the substrate.

## Internal use

18.15 All existing plaster should be removed and, if necessary, repairs completed before application.

18.16 Wallreform should be applied evenly to produce the required thickness.

18.17 A topcoat of finishing plaster may be applied after the Wallreform has dried (depends on thickness, but typically 4 hours per 10 mm thickness). Permanent decoration should not be applied until the plaster and Wallreform have dried out thoroughly.

## Technical Investigations

The following is a summary of the technical investigations carried out on Wallreform.

### 19 Tests

19.1 Tests were carried out to determine: product characteristics (in accordance with MOAT No 21 : 1982, MOAT No 22 : 1988 and BS EN 1015-11 : 1999)

water vapour permeability (in accordance with BS 3177 : 1959)

thermal conductivity (in accordance with BS 874-2.1 : 1986).

19.2 Tests were carried out on Wallreform in conjunction with a variety of coatings in accordance with MOAT No 22 : 1988 to determine:

resistance to heat/spray cycling

resistance to freeze/thaw

impact resistance

bond strengths to various substrates.

19.3 An examination was made of data relating to: fire propagation to BS 476-6 : 1989 surface spread of flame to BS 476-7 : 1997.

### 20 Other investigations

20.1 The manufacturing process, the methods adopted for quality control, and details of the quality and composition of the materials used, were examined.

20.2 The practicability of installation and the effectiveness of detailing techniques were examined.

20.3 Visits were made to existing installations where the product was in service.

## Bibliography

BS 476-6 : 1989 *Fire tests on building materials and structures — Method of test for fire propagation for products*

BS 476-7 : 1997 *Fire tests on building materials and structures — Method of test to determine the classification of the surface spread of flame of products*

BS 874-2.1 : 1986 *Methods for determining thermal insulating properties — Tests for thermal conductivity and related properties — Guarded hot-plate method*

BS 3177 : 1959 *Method for determining the permeability to water vapour of flexible sheet materials used for packaging*

BS 3921 : 1985 *Specification for clay bricks*

BS 5262 : 1991 *Code of practice for external renderings*

BS 5628-3 : 2001 *Code of practice for use of masonry — Materials and components, design and workmanship*

BS 8000-10 : 1995 *Workmanship on building sites — Code of practice for plastering and rendering*

BS EN 1015-11 : 1999 *Methods of test for mortar for masonry — Determination of flexural and compressive strength of hardened mortar*

MOAT No 21 : 1982 *Directives for the Assessment of Ceramic Tile Adhesives*

MOAT No 22 : 1988 *UEAtc Directives for the Assessment of External Insulation Systems for Walls (Expanded Polystyrene Insulation Faced with a Thin Rendering)*

### 21 Conditions

21.1 This Certificate:

- (a) relates only to the product that is described, installed, used and maintained as set out in this Certificate;
- (b) is granted only to the company, firm or person identified on the front cover — no other company, firm or person may hold or claim any entitlement to this Certificate;
- (c) has to be read, considered and used as a whole document — it may be misleading and will be incomplete to be selective;
- (d) is copyright of the BBA.

21.2 References in this Certificate to any Act of Parliament, Regulation made thereunder, Directive or Regulation of the European Union, Statutory Instrument, Code of Practice, British Standard, manufacturers' instructions or similar publication, shall be construed as references to such publication in the form in which it was current at the date of this Certificate.

21.3 This Certificate will remain valid for an unlimited period provided that the product and the manufacture and/or fabricating process(es) thereof:

- (a) are maintained at or above the levels which have been assessed and found to be satisfactory by the BBA;

(b) continue to be checked by the BBA or its agents; and

(c) are reviewed by the BBA as and when it considers appropriate.

21.4 In granting this Certificate, the BBA makes no representation as to:

- (a) the presence or absence of any patent or similar rights subsisting in the product or any other product;
- (b) the right of the Certificate holder to market, supply, install or maintain the product; and
- (c) the nature of individual installations of the product, including methods and workmanship.

21.5 Any recommendations relating to the use or installation of this product which are contained or referred to in this Certificate are the minimum standards required to be met when the product is used. They do not purport in any way to restate the requirements of the Health & Safety at Work etc Act 1974, or of any other statutory, common law or other duty which may exist at the date of this Certificate or in the future; nor is conformity with such recommendations to be taken as satisfying the requirements of the 1974 Act or of any present or future statutory, common law or other duty of care. In granting this Certificate, the BBA does not accept responsibility to any person or body for any loss or damage, including personal injury, arising as a direct or indirect result of the installation and use of this product.



In the opinion of the British Board of Agrément, Wallreform is fit for its intended use provided it is installed, used and maintained as set out in this Certificate. Certificate No 02/3951 is accordingly awarded to Walltransform.

On behalf of the British Board of Agrément

A handwritten signature in black ink, appearing to read 'P. Q. Newson', is written over a light grey background.

Date of issue: 30th August 2002

Chief Executive